



18335/O -B

DATOS TÉCNICOS

LUMINARIA FIJA DE SUSPENSIÓN.

CORRIENTE DE ENTRADA AC 230V 50-60Hz.

1 DOB LED INTEGRADO 16W.

TECHNICAL DATA

FIXED SUSPENSION LUMINAIRE.

INPUT CURRENT AC 230V 50-60Hz.

1 INTEGRATED LED DOB 16W.

4

Extraer el componente anti tracción Z, que se encuentra en el extremo del cable y reservarlo para el ensamblaje final de la luminaria. Introducir el extremo del cable por el centro del conjunto ensamblado saliendo por el extremo del tubo F. Fijar la parte H con los 4 tornillos y posteriormente cerrar con la cúpula difusora G, haciendo coincidir los 3 agujeros con los tres botones del ensamblaje realizando un click.

Remove the anti-traction component Z, located at the end of the cable and reserve it for the final assembly of the luminaire. Insert the end of the cable through the center of the assembly assembled by the end of the pipe F. Fix the part H with the 4 screws and then close with the diffuser dome G, matching the 3 holes with the three buttons of the assembly with a click.

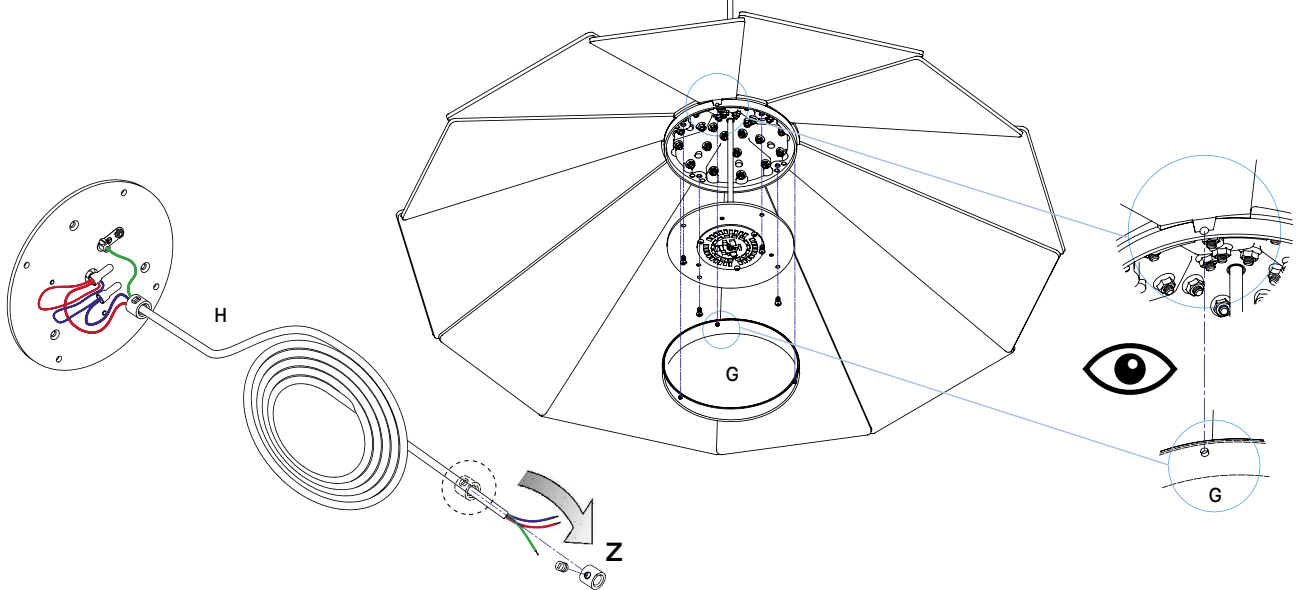

Accesorios compatibles

Compatible accessories

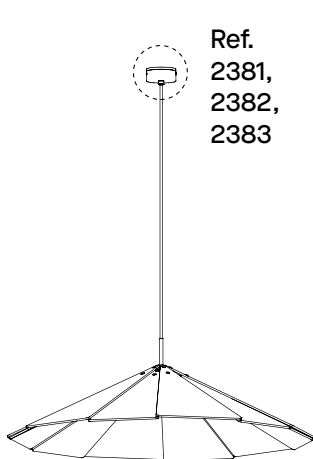

Ref.
2381,
2382,
2383

Base de conexión a techo.
Ceiling connection base.

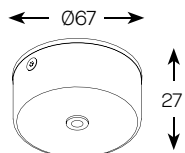

Ref. 2381, 2382, 2383

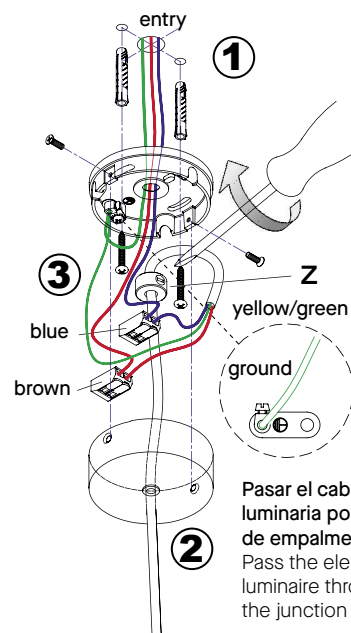
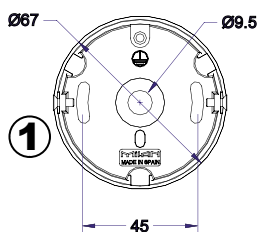

Pasar el cable eléctrico de la luminaria por el agujero hacia la caja de empalmes.
Pass the electric cable of the luminaire through the hole towards the junction box.